

UM200B

FREQUENCY-AGILE UHF BELT-PACK TRANSMITTER

OPERATING INSTRUCTIONS and trouble-shooting guide

LECTROSONICS, INC.

Rio Rancho, NM

TABLE OF CONTENTS

| | |
|---|------------|
| INTRODUCTION | 3 |
| GENERAL TECHNICAL DESCRIPTION | 4 |
| CONTROLS AND FUNCTIONS | 6 |
| BATTERY INSTALLATION | 8 |
| OPERATING INSTRUCTIONS | 8 |
| OPERATING NOTES | 9 |
| ADJUSTING THE TRANSMITTER FREQUENCY | 9 |
| MICROPHONE CORD TERMINATION | 10 |
| 5-PIN INPUT JACK WIRING | 11 |
| A6U UHF ANTENNA | 13 |
| TROUBLESHOOTING | 14 |
| SPECIFICATIONS AND FEATURES | 15 |
| SERVICE AND REPAIR | 16 |
| RETURNING UNITS FOR REPAIR | 16 |
| WARRANTY | Back cover |

The UM200B transmitter is FCC type accepted under Part 74: 470-608MHz and 614-802MHz.

INTRODUCTION

Thank you for selecting the Lectrosonics UM200B frequency agile, belt-pack transmitter. The UM200B combines over 80 years of engineering experience with the very latest components, in a design that addresses the most demanding professional applications.

The design of the UM200B was the direct result of numerous conversations with users, staging and touring companies and dealers across the US. The specific concerns and needs brought up in these conversations led directly to the development of the operational features offered on the UM200B. Two hundred fifty six frequencies are user selectable in 100kHz steps to alleviate interference problems in travelling venues, and the low frequency roll-off is user adjustable to adapt to varying acoustic environments and preferences.

The UM200B is a rugged, machined aluminum package with a removable, spring loaded belt clip. The input section provides a correct input tap for virtually any microphone or line level audio source. 5 Volts of bias voltage is available to power electret mics with either positive or negative bias. Level indicating LEDs are provided on the control panel to make level settings quick and accurate, without having to view the receiver. The battery compartment accepts any 9 Volt alkaline battery and makes a positive connection via self-adjusting contacts. The antenna is a detachable, locking 1/4 wavelength flexible bronze cable that connects to a 50 Ohm SMA port on the transmitter.

Only the UM200B transmitter is covered in this manual. Companion receivers are covered in separate manuals. The UM200B will operate with any 200 Series Lectrosonics receiver in the same frequency group.

GENERAL TECHNICAL DESCRIPTION

The UM200B transmitters are comprised of a number of functional sub-systems as shown in the block diagram below.

GENERAL

The 200 system uses 75kHz wide deviation for an extremely high signal to noise ratio. The transmitter circuits are all regulated to allow full output power from the beginning (9 Volts) to the end (6.5 Volts) of battery life. The input amplifier uses a Motorola 33078 op amp for ultra low noise operation. It is gain controlled with a wide range input compressor which cleanly limits input signal peaks over 30dB above full modulation.

DUAL BAND COMPANDOR

Traditionally, compandors have been a source of distortion in wireless microphone systems. The basic problem with conventional systems is that the attack and decay times are always a compromise. If the time constants are fast, high frequency transients will not be distorted, but this will cause low frequency distortion. If the time constants are slower, low frequency audio distortion will be low, but high frequency transients will then be distorted. The 200 system introduces an entirely new approach to solving this basic problem, called "dual-band companding."

There are actually two separate compandors in the 200 system, one for high frequencies and one for low frequencies. A crossover network separates the frequency bands at 1kHz with a 6dB per octave slope, followed by separate high and low frequency compandors. The attack and release times in the high frequency compandor are fast enough to keep high frequency transient distortion at a low level, and the low frequency compandor uses slower time constants, reducing low frequency distortion to well below that of a conventional compandor.

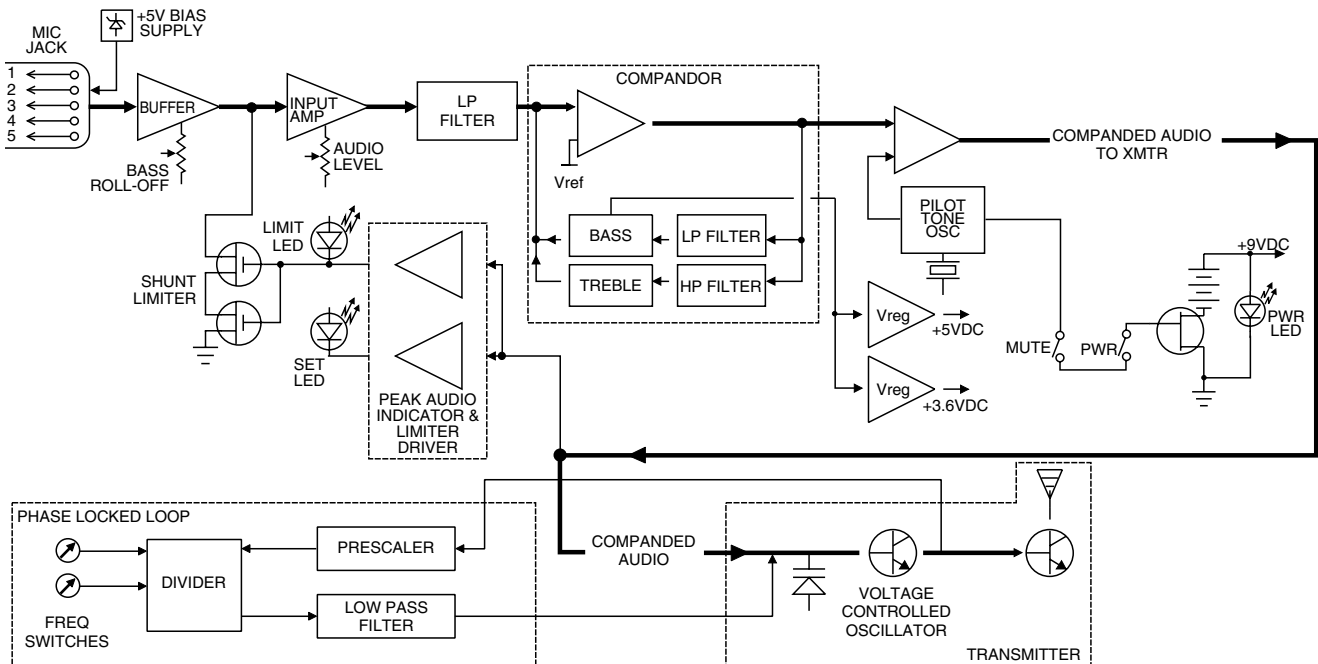

UM200B Block Diagram

NO PRE-EMPHASIS/DE-EMPHASIS

The signal to noise ratio of the 200 system is high enough to preclude the need for conventional pre-emphasis (HF boost) in the transmitter and de-emphasis (HF roll off) in the receiver. Pre-emphasis and de-emphasis in an FM radio system usually provides about a 10dB improvement in the signal to noise ratio of the system, but the high frequency boost in the transmitter must be removed in a purely complementary manner or else the frequency response of the original audio signal will be altered.

Pre-emphasis can also cause distortion in the receiver. As this signal is passed through the IF filters in the receiver, distortion can be produced, most noticeable at full modulation. De-emphasis cannot be applied until the signal is converted into audio, so there is no way around this problem short of eliminating pre-emphasis altogether. Neither of these problems occur in the 200 system. The dual-band compandor in the 200 Series system essentially provides a dynamic pre-emphasis/de-emphasis function with extremely low distortion.

PILOT TONE SQUELCH

The 200 system utilizes an ultrasonic tone modulation of the carrier to operate the receiver squelch. This “pilot tone” consists of a 32kHz signal mixed with the audio signal following the microphone preamp, just after the compandor, to control the audio output muting of the receiver. The pilot tone is filtered out of the audio signal immediately after the detector in the receiver so that it does not influence the compandor or various gain stages. The basic benefit of the pilot tone squelch system is that the receiver will remain muted until it receives the pilot tone from the matching transmitter, even if a strong RF signal is present on the carrier frequency of the system. This is extremely important in applications that include an automatic microphone mixer.

WIDE-BAND DEVIATION

$\pm 75\text{kHz}$ deviation improves the capture ratio, signal to noise ratio and AM rejection of a wireless system dramatically, compared to the more commonly used $\pm 15\text{kHz}$ deviation.

LONG BATTERY LIFE

High efficiency circuits throughout the design allow over 4.5 hours of operation using a single 9 Volt alkaline battery. (A 9V lithium battery will provide over 14 hours of operation.) The battery compartment is a unique mechanical design which automatically adjusts to fit any brand of battery. The battery contacts are spring loaded to prevent “rattle” as the unit is handled.

FREQUENCY AGILITY

The transmitter section uses a synthesized, frequency selectable main oscillator. The frequency is extremely stable over a wide temperature range and over time.

Two rotary switches, located on the side panel of the unit, provide 256 frequencies in 100kHz steps over a 25.5MHz range. This alleviates carrier interference problems in mobile or travelling applications.

ANTENNA

At UHF frequencies, where wavelengths and antennas are shorter than at VHF frequencies, a resonant length wire is preferred over using the microphone cable as the antenna. The antenna on the UM200B consists of a flexible 1/4 wavelength bronze cable, detachable via an SMA connector. The impedance of this connector is 50 Ohms.

CONTROLS AND FUNCTIONS

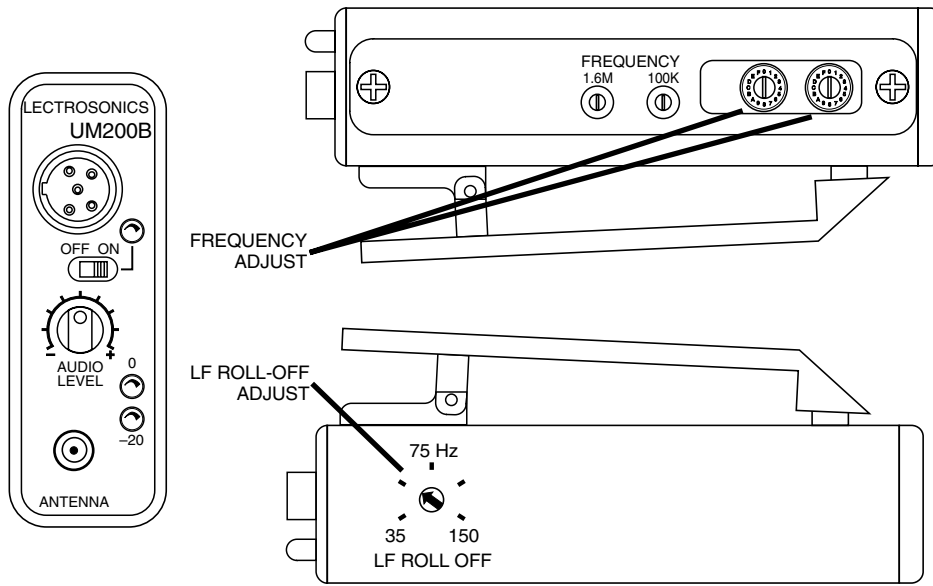

INPUT JACK

The input on the UM200B accommodates virtually every lavalier, hand-held or shotgun microphone available. Line level signals can also be accommodated. Use a Switchcraft TA5F connector on the cord. **See the separate sheet titled “Transmitter 5-Pin Input Jack Wiring” regarding the correct connections for various microphones, and other sources.**

ON/OFF SWITCH

Turns the battery power on and off. Even when the switch is turned off or on abruptly, the pilot tone muting system prevents “thumps” or transients from occurring.

“ON” LAMP

Glowes brightly when the battery is good and the ON/OFF switch is ON. A weak or dim lamp means that the battery is weak. When the light goes out there is about 15 to 30 minutes of operation left. If the lamp fails to light, the battery should be replaced.

The “ON” lamp is connected to a precision battery test circuit that continuously monitors battery voltage. The LED is at full brightness with a new 9 Volt alkaline battery. As the battery voltage drops during use, the LED brightness will also decrease. After about 4.5 hours of operation the battery voltage will be about 6.5 Volts and the LED will be completely out.

FREQUENCY ADJUST

These two rotary switches adjust the center frequency of the carrier. The 1.6M is a coarse adjustment and the 100K is the fine adjustment. Each transmitter is factory aligned at the center of its operating range. The default position of the frequency select switches is in the center of the transmitter’s range.

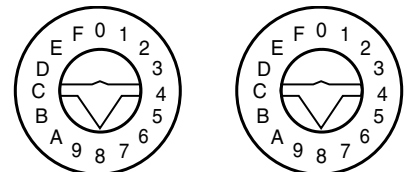

Since the internal circuits are all tightly regulated and the RF output stage has a separate discrete regulator, the transmitter will continue to operate to a battery voltage of 6.5 Volts. From 6.5 Volts to 6 Volts, the transmitter will still operate, but with degraded performance. Please note that a weak battery will sometimes light the POWER LED immediately after turn on, but will soon discharge to the point where the LED will go out, just like a flashlight with “dead” batteries.

The combination of an accurate battery condition indicator and regulation of all internal circuits provides much longer battery life, as well as consistent performance over the life of the battery.

MODULATION LEDS

Indicate the proper setting of the MIC LEVEL control.

“-20” LED -- Flickers or glows when sufficient audio is present.

“0” LED -- Lights up when the input level is high enough to cause limiting. The input limiter has a very high overload threshold (over 30 dB). Generally speaking, some limiting is desirable in normal operation to improve the signal to noise ratio of the system. The limiting action is not audible and does not create distortion. A highly trained ear would hear only the compression of the peaks in the audio signal, which is desirable with most tape recorders and many sound reinforcement systems.

AUDIO LEVEL

Used to adjust the audio input level for the proper modulation.

ANTENNA

The flexible wire antenna supplied with the transmitter is cut to 1/4 wavelength of the center of the frequency block (the frequency range) of the transmitter. It is removable via an SMA connector. The SMA connector is a 50 Ohm RF port which can also be connected directly to test equipment. Replacement antennas are available in pre-cut lengths for specific frequency blocks, or as a kit with instructions to cut the antenna for any frequency block.

ADJUSTABLE LOW FREQUENCY ROLL-OFF

A 18dB per octave low frequency roll-off is provided in the audio section, with the -3dB point adjustable from 35Hz to 150Hz. The actual roll-off frequency will vary somewhat according to the low frequency response of the mic capsule being used.

The low frequency roll-off control is used to prevent undesirable subsonic (or very low frequency) audio, often produced by air conditioning systems, automobile traffic and other sources from causing the compandor to mistrack. Excessive low frequency content in the audio input can cause “pumping and breathing” of background noise or modulation of the program audio in recording applications. In sound reinforcement systems, excessive low frequency content can cause excessive power amplifier drain or even damage to loudspeaker systems. By rotating the control clockwise, the hinge point of the roll-off is increased to reduce the level of low frequencies. In controlled situations, such as a motion picture production set indoors where environmental noise is minimal, the control can be rotated counter-clockwise to permit low frequency audio to be captured.

THE BELT CLIP

The belt clip may be removed for special applications by removing one screw.

USE ONLY THE SCREW THAT IS SUPPLIED

The circuitry is tightly packed into this unit. A longer screw will permanently damage the transmitter! Use only Lectrosomics PN:28528 which is a Phillips head, 4-40 x 3/16", FL100 screw.

BATTERY INSTALLATION

The transmitter is powered by a standard alkaline or lithium 9 Volt battery. It is important that you use **ONLY** an ALKALINE or LITHIUM battery for longest life. Standard zinc-carbon batteries marked “**heavy-duty**” or “**long-lasting**” are not adequate. Ni-cad rechargeable batteries will only provide 1.5 hours of operation, or less, and will run down quite abruptly. Alkaline batteries provide over 4.5 hours of operation. Lithium batteries can be used to provide up to 14 hours. Care should be taken not to leave a fully discharged lithium battery in the transmitter, as swelling of the battery can make it difficult to remove from the compartment. The battery status circuitry is designed for the voltage drop over the life of alkaline batteries.

To open the battery compartment, press outward on the cover door in the direction of the arrow as shown in the drawing. Only firm, sliding pressure is needed to open and close the battery door. Swing the door open and take note of the polarity marked inside showing the location of the positive (+) and negative (-) terminals. You can see the large and small contact holes inside the battery compartment with the door open.

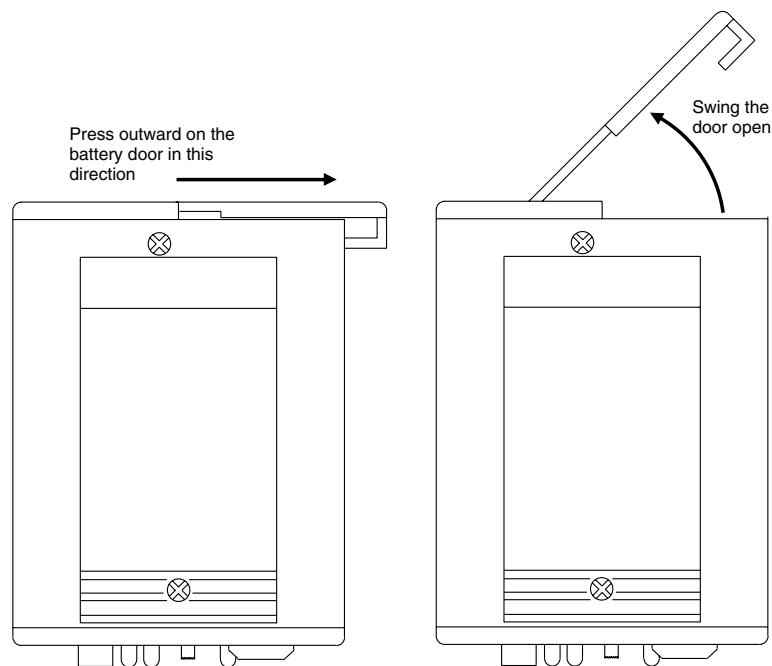

Insert the battery correctly and close the cover by pressing the door closed and across, reversing the opening procedure illustrated above. If the battery is inserted incorrectly, the door will not close. Do not force the door closed.

OPERATING INSTRUCTIONS

- 1) Install a fresh battery according to the instructions above.
- 2) Insert the microphone plug into the input jack, aligning the pins; be sure that the connector locks in.
- 3) Attach the antenna to the SMA connector on the top of the transmitter.
- 4) Mute the sound system.
- 5) Turn the transmitter power switch to the “ON” position.
- 6) Position the microphone in the location you will use in actual operation.

- 7) While speaking or singing at the same voice level that will actually be used, observe the MODULATION LEDs. Adjust the AUDIO LEVEL control knob until the LEDs begin to light. Start at a low setting where neither LED lights as you speak. Gradually, turn the gain up until one LED lights, then the other.
- The -20 LED lights when the audio level is about 12dB below full modulation. The “0” LED lights when the limiter begins to operate. There is over 30dB of limiting range without overload above the “0” LED, so it is desirable that the it lights up 5% to 10% of the time during use.
- 8) Once the gain has been adjusted, the audio system audio can be turned on to make level adjustments. Set the power switch to the ON position and adjust the receiver and/or sound system level as required. **Please note, there will be a delay between the moment the switch is thrown and the time when audio will actually appear at the receiver output.** This intentional delay eliminates turn on thumps, and is controlled by the pilot tone squelch control.

OPERATING NOTES

The AUDIO LEVEL control knob should not be used to control the volume of your sound system or recorder levels. This gain adjustment matches the transmitter gain with the user’s voice level and microphone positioning.

If the audio level is too high — both LEDs will light frequently or stay lit. This condition may reduce the dynamic range of the audio signal.

If the audio level is too low — neither LED will light, or the -20 LED will light dimly. This condition may cause hiss and noise in the audio, or pumping and breathing in the background noise.

The first LED turns on 12dB below full deviation. The “0” LED turns on at full deviation and indicates that the input shunt compressor is operating. The input limiter will handle peaks over 30dB above full modulation, regardless of the gain control setting. The limiter uses a true absolute value circuit to detect both positive and negative peaks. The attack time is 5 milliseconds and the release time is 200 milliseconds. Occasional limiting is desirable, indicating that the gain is correctly set and the transmitter is fully modulated for optimum signal to noise ratio.

Different voices will usually require different settings of the AUDIO LEVEL control, so check this adjustment as each new person uses the system. If several different people will be using the transmitter and there is not time to make the adjustment for each individual, adjust it for the loudest voice.

ADJUSTING THE TRANSMITTER FREQUENCY

If you are experiencing interference from another signal on your frequency, you may want to change the operating frequency of your system. The left switch changes the operating frequency by 1.6 MHz per step and the right switch changes it 100 kHz per step. If you are experiencing interference, change the operating frequency in 100 kHz steps to find a clear channel. If it is not possible to find a clear channel using the 100 kHz switch, return it to its original position and change the 1.6 MHz switch by one click then try the 100 kHz switch again.

To gain access to these switches, slide the access door sideways with a fingernail.

Note: With the UDR200A receiver, these switches also appear on the front panel of the receiver. Normally, you should set the transmitter switches to match the receiver switch settings.

With the UDR200B receiver, the front panel LED character display will indicate the correct transmitter switch settings.

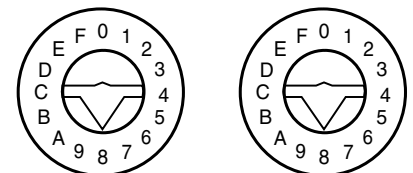

MICROPHONE CORD TERMINATION

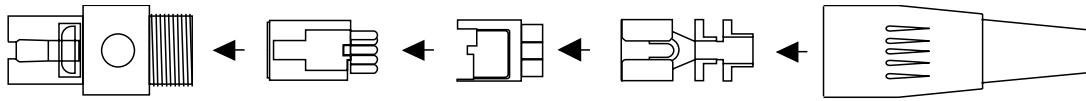

TA5F Connector Assembly

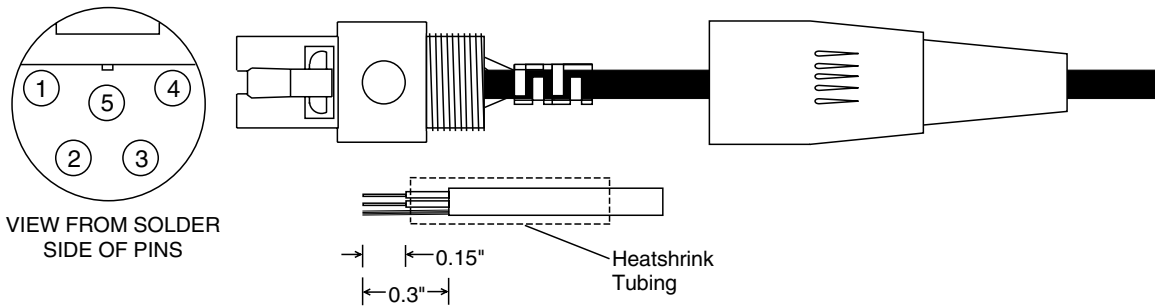

Mic Cord Stripping Instructions

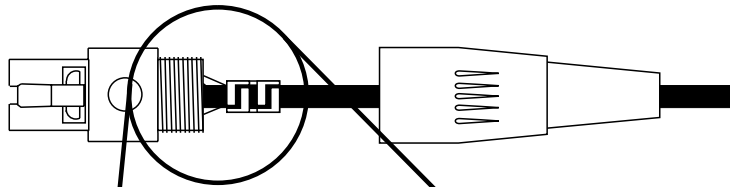

Caution!

Do not allow the shield wire to touch any metal part of the connector shell.

The shield wire is the antenna on VHF models and poor operating range will result.

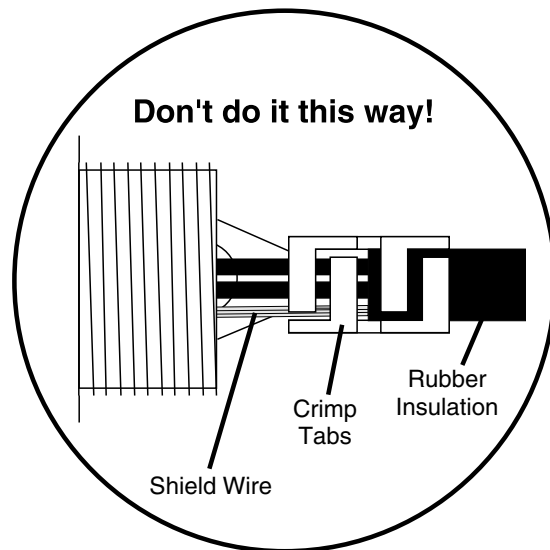
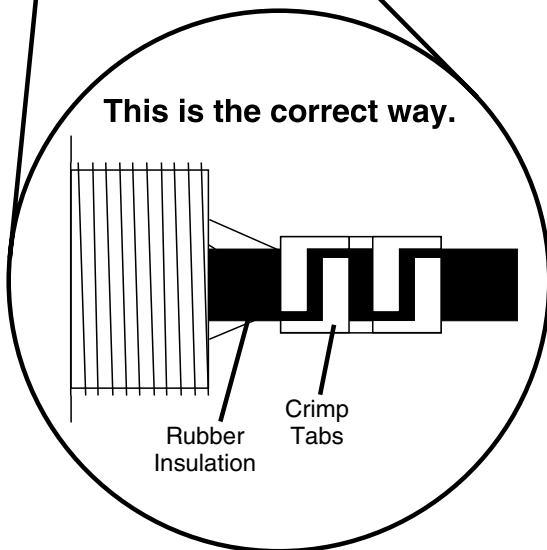

Note: This termination is required on VHF transmitters and will still work fine on UHF transmitters.

5-PIN INPUT JACK WIRING

The wiring diagrams shown on the next page represent the basic wiring necessary for the most common types of microphones and other audio inputs. Some microphones may require extra jumpers or a slight variation on the diagrams shown.

Caution - When wiring the connector, do not use the connector body for any electrical connections. A common mistake is to use the connector body as an audio ground. The connector body is already used as an RF ground on VHF models and no other use is permitted.

It's virtually impossible to keep completely up to date on changes that other manufacturers make to their products. It is possible that you may encounter a microphone that differs from these instructions. If this occurs please call our toll-free number listed on page 13 of this instruction manual. Our service department can answer your questions regarding microphone compatibility.

When used on a wireless transmitter, the microphone element is in the proximity of the RF coming from the transmitter. The nature of electret microphones makes them sensitive to RF, which can cause problems with the microphone/transmitter compatibility. If the electret microphone is not designed properly for use with wireless transmitters, it may be necessary to install a chip capacitor in the mic capsule or connector to block the RF from entering the electret capsule. This modification is shown on the next page.

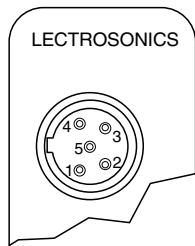

**Transmitter
Input Jack**

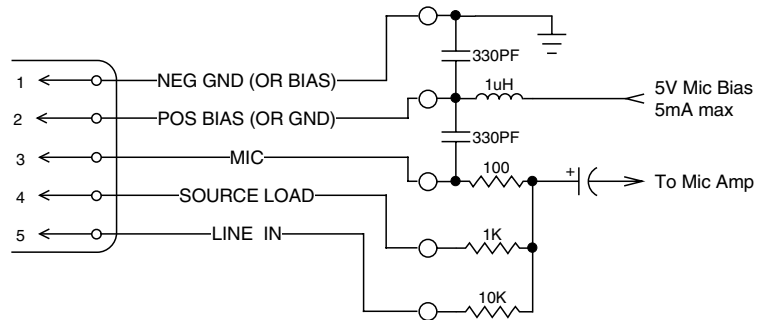

UHF Transmitter Equivalent Input Circuit

VHF transmitters use the shield of the microphone cord as the antenna. The UM200B uses a 1/4 wave flexible wire to radiate the RF signal. There is really not much difference between these two approaches, with respect to the effect of the RF on the microphone capsule. Even in transmitters that utilize a "dangling wire," the microphone is still part of the "ground plane" and is therefore still in the antenna circuit.

- PIN 1** Shield (ground) for positive biased electret lavalier microphones. Bias voltage source for negative biased electret lavalier microphones. Shield (ground) for dynamic microphones and line level inputs.
- PIN 2** Shield (ground) for negative biased electret lavalier microphones. Bias voltage source for positive biased electret lavalier microphones.
- PIN 3** Low impedance microphone level input for dynamic microphones. Also accepts hand-held electret microphones provided the microphone has its own built-in battery.
- PIN 4** 1K Ohm source load for non-Lectrosonics electret microphones. Use in conjunction with other pins to provide attenuation of high level input signals.
- PIN 5** High impedance, line level input for tape decks, mixer outputs, musical instruments, etc.

RF BYPASSING

Some mics require RF protection to keep the radio signal from affecting the capsule, even though the transmitter input circuitry is already RF bypassed (see schematic diagram).

If the mic is wired as directed, and you are having difficulty with squealing, high noise, or poor frequency response; RF is likely to be the cause.

The best RF protection is accomplished by installing RF bypass capacitors at the mic capsule. If this is not possible, or if you are still having problems, capacitors can be installed on the mic wires inside the TA5F connector housing.

Install the capacitors as follows: Use 330 pF capacitors. Capacitors are available from Lectrosonics. Please specify the part number for the desired lead style.

Leaded capacitors: P/N 15117

Leadless capacitors: P/N SCC330P

All Lectrosonics lavalier mics are already bypassed and do not need any additional capacitors installed for proper operation.

BODY GROUND

Caution - When wiring the connector, do not use the connector body for any electrical connections. A common mistake is to use the connector body as an audio ground. The connector body is already used as an RF ground on VHF models and no other use is permitted.

LINE LEVEL SIGNALS

The normal hookup for line level signals is: Signal Hot to pin 5, Signal Gnd to pin 1, pin 4 jumped to pin 1, and pin 3 jumped to pin 1. This gives a 40dB attenuator that allows signal levels much higher than 3V to be applied without distortion.

If more headroom is needed, insert a 100k resistor in series with pin 5. Put this resistor inside the TA5F connector to minimize noise pickup.

If lower than normal line levels (less than 1V) are expected, use this hookup: Signal Hot to pin 5, Signal Gnd to pin 1, and pin 4 jumpered to pin 1. This provides a 20dB attenuator allowing signals as high as 3V to be applied without distortion.

WIRING HOOKUPS FOR DIFFERENT SOURCES

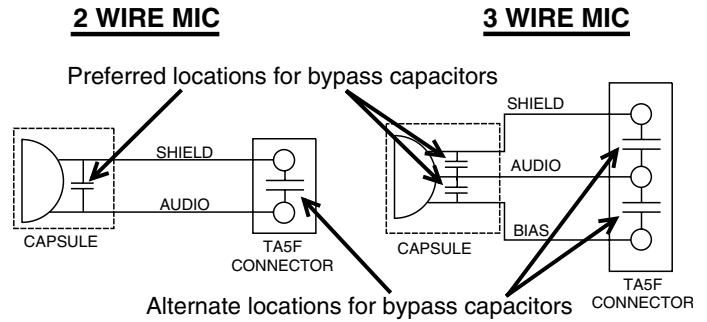
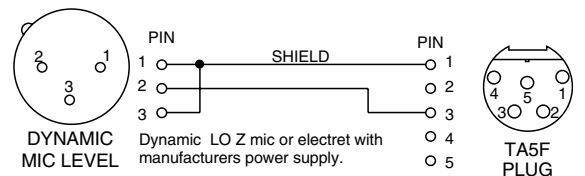
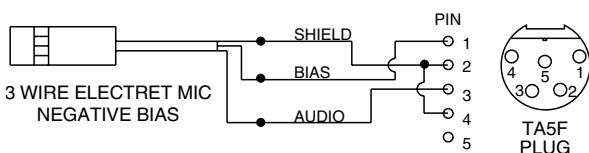
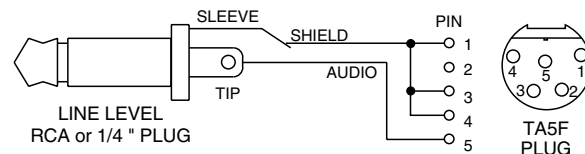
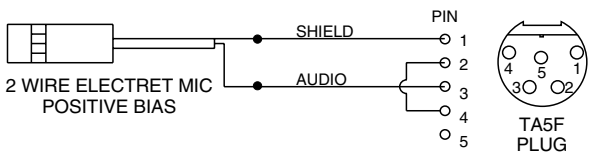
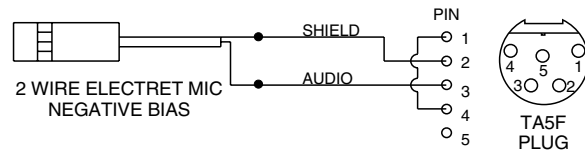
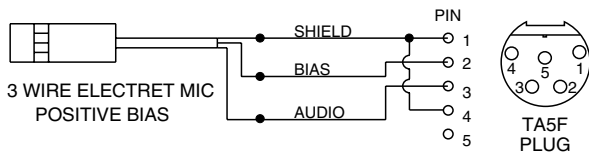

A6U UHF ANTENNA

This is a full size cutting template. Lay the actual antenna on top of this drawing and cut at the mark for the desired frequency group.

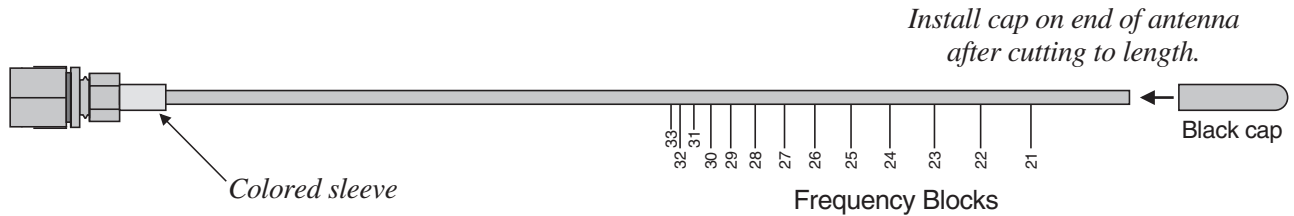

Kits are shipped from the factory with caps of the various colors plus a black cap. After cutting the antenna to the desired block length, select the properly colored cap and cut off the closed end to make the colored sleeve. Slide the colored sleeve onto the antenna as shown above then slide the black cap onto the cut end of the antenna.

| BLOCK | FREQUENCY RANGE | ANT SLEEVE COLOR | ANTENNA WHIP LENGTH |
|-------|-------------------|------------------|---------------------|
| 21 | 537.600 - 563.100 | Brown | 4.74" |
| 22 | 563.200 - 588.700 | Red | 4.48" |
| 23 | 588.800 - 614.300 | Orange | 4.24" |
| 24 | 614.400 - 639.900 | Yellow | 4.01" |
| 25 | 640.000 - 665.500 | Green | 3.81" |
| 26 | 665.600 - 691.100 | Blue | 3.62" |
| 27 | 691.200 - 716.700 | Violet (Pink) | 3.46" |
| 28 | 716.800 - 742.300 | Grey | 3.31" |
| 29 | 742.400 - 767.900 | White | 3.18" |
| 30 | 768.000 - 793.500 | Orange/Black | 3.08" |
| 31 | 793.600 - 819.100 | Orange/Brown | 2.99" |
| 32 | 819.200 - 844.700 | Orange/Red | 2.92" |
| 33 | 844.800 - 865.000 | Orange/Orange | 2.87" |

The sleeve color follows the standard resistor color code for the second numeral in the group number.

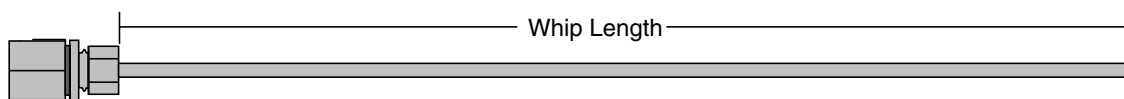

Measure the length of the whip that protrudes outside of the SMA connector.

IMPORTANT*TROUBLESHOOTING**

Before going through the following chart, be sure that you have a good battery in the transmitter. It is important that you follow these steps in the sequence listed.

| SYMPTOM | POSSIBLE CAUSE |
|--|---|
| TRANSMITTER BATTERY LED OFF | <ol style="list-style-type: none"> 1) Battery is inserted backwards. 2) Battery is dead. |
| NO TRANSMITTER MODULATION LEDS | <ol style="list-style-type: none"> 1) Gain control turned all the way down. 2) Battery is in backwards. Check power LED. 3) Mic capsule is damaged or malfunctioning. 4) Mic cable damaged or mis-wired. |
| RECEIVER RF LAMP OFF | <ol style="list-style-type: none"> 1) Transmitter not turned on. 2) Transmitter battery is dead. 3) Receiver antenna missing or improperly positioned. 4) Transmitter and receiver not on same frequency. Check switches/display on transmitter and receiver. 5) Operating range is too great. 6) Transmitter antenna not connected |
| NO SOUND (OR LOW SOUND LEVEL), RECEIVER MOD LEVEL LEDS ARE ON | <ol style="list-style-type: none"> 1) Receiver output level set too low. 2) Receiver output is disconnected; cable is defective or mis-wired. 3) Sound system or recorder input is turned down. |
| DISTORTED SOUND | <ol style="list-style-type: none"> 1) Transmitter gain (audio level) is far too high. Check mod level lamps on transmitter and receiver as it is being used. (refer to pages 8/9 for details on gain adjustment) 2) Receiver output may be mis-matched with the sound system or recorder input. Adjust output level on receiver to the correct level for the recorder, mixer or sound system. 3) Excessive wind noise or breath "pops." Re-position microphone and/or use a larger windscreen. 4) Transmitter is not set to same frequency as receiver. Check that frequency select switches on receiver and transmitter match. |
| HISS AND NOISE -- AUDIBLE DROPOUTS | <ol style="list-style-type: none"> 1) Transmitter gain (audio level) far too low. 2) Receiver antenna missing or obstructed. 3) Transmitter antenna missing. 4) Operating range too great. |
| EXCESSIVE FEEDBACK | <ol style="list-style-type: none"> 1) Transmitter gain (audio level) too high. Check gain adjustment and/or reduce receiver output level. 2) Transmitter too close to speaker system. 3) Mic is too far from user's mouth. |

SPECIFICATIONS AND FEATURES

| | |
|---|--|
| Operating frequencies: | 537.600 to 588.700 MHz 614.400 to 793.500 MHz |
| Frequency selection: | 256 frequencies in 100kHz steps |
| RF Power output: | 70 mW (nominal) |
| Pilot tone: | 32.764 kHz (± 2 Hz); 5kHz deviation |
| Frequency stability: | $\pm 0.002\%$ |
| Deviation: | ± 75 kHz (max) |
| Spurious radiation: | 90 dB below carrier |
| Equivalent input noise: | -126 dBV |
| Input level: | Nominal 2 mV to 300 mV, before limiting. Greater than 50V maximum, with limiting. |
| Input impedance: | Taps provided for 500, 1k, 10k Ohm |
| Input compressor: | Soft compressor, >30 dB range |
| Gain control range: | 43 dB; semi-log rotary control |
| Modulation indicators: | Dual LEDs indicate modulation level 12dB below limiting and at the onset of limiting. |
| Low frequency roll-off adjustment: | -18dB/octave; 35Hz to 150Hz |
| Controls: | 2 position "OFF-ON" slide switch for noiseless turn on/turn off operation. Front panel knob adjusts audio gain. Recessed control on side panel adjusts low frequency rolloff. Rotary switches on side panel adjust transmitter frequency. |
| Audio Input Jack: | Switchcraft 5 pin locking (TA5F) |
| Antenna: | Detachable, flexible wire supplied. 50 Ohm port allows connection to test equipment. |
| Battery: | Precision compartment auto-adjusts to accept any known alkaline 9 Volt battery. (We've tried 125 different ones!) |
| Battery Life: | 4.5 hours (alkaline); 14 hours (lithium) |
| Weight: | 6.3 ozs. including battery |
| Dimensions: | 3.1 x 2.4 x .75 inches |

Emission Designator: 180KF3E

Specifications subject to change without notice.

SERVICE AND REPAIR

If your system malfunctions, you should attempt to correct or isolate the trouble before concluding that the equipment needs repair. Make sure you have followed the setup procedure and operating instructions. Check out the interconnecting cords and then go through the TROUBLE SHOOTING section in the manual

We strongly recommend that you **do not** try to repair the equipment yourself and **do not** have the local repair shop attempt anything other than the simplest repair. If the repair is more complicated than a broken wire or loose connection, send the unit to the factory for repair and service. Don't attempt to adjust any controls inside the units. Once set at the factory, the various controls and trimmers do not drift with age or vibration and never require readjustment. **There are no adjustments inside that will make a malfunctioning unit start working.**

LECTROSONICS service department is equipped and staffed to quickly repair your equipment. In-warranty repairs are made at no charge in accordance with the terms of the warranty. Out of warranty repairs are charged at a modest flat rate plus parts and shipping. Since it takes almost as much time and effort to determine what is wrong as it does to make the repair, there is a charge for an exact quotation. We will be happy to quote approximate charges by phone for out of warranty repairs.

RETURNING UNITS FOR REPAIR

You will save yourself time and trouble if you will follow the steps below:

- A.** DO NOT return equipment to the factory for repair without first contacting us by letter or by phone. We need to know the nature of the problem, the model number and the serial number of the equipment. We also need a phone number where you can be reached 8 am to 4 pm (Mountain Standard Time).
- B.** After receiving your request, we will issue you a return authorization number (R.A.). This number will help speed your repair through our receiving and repair departments. The return authorization number must be clearly shown on the outside of the shipping container.
- C.** Pack the equipment carefully and ship to us, shipping costs prepaid. If necessary, we can provide you with the proper packing materials. UPS is usually the best way to ship the units. Heavy units should be "double-boxed" for safe transport.
- D.** We also strongly recommend that you insure the equipment, since we cannot be responsible for loss of or damage to equipment that you ship. Of course, we insure the equipment when we ship it back to you.

Mailing address:

Lectrosonics, Inc.
PO Box 15900
Rio Rancho, NM 87174
USA

Shipping address:

Lectrosonics, Inc.
581 Laser Rd.
Rio Rancho, NM 87124
USA

Telephones:

Regular: (505) 892-4501
Toll Free (800) 821-1121
FAX: (505) 892-6243

World Wide Web: <http://www.lectrosonics.com>

Email: sales@lectrosonics.com

This page intentionally blank.

LIMITED ONE YEAR WARRANTY

The equipment is warranted for one year from date of purchase against defects in materials or workmanship provided it was purchased from an authorized dealer. This warranty does not cover equipment which has been abused or damaged by careless handling or shipping. This warranty does not apply to used or demonstrator equipment.

Should any defect develop, we will, at our option, repair or replace any defective parts without charge for either parts or labor. If we cannot correct the defect in your equipment, we will replace it at no charge with a similar new item. We will pay for the cost of returning your merchandise to you.

This warranty applies only to items returned to us, shipping costs prepaid, within one year from the date of purchase.

This warranty gives you specific legal rights. You may have additional legal rights which vary from state to state.

LECTROSONICS, INC.

581 LASER ROAD
RIO RANCHO, NM 87124 USA

June 21, 2000